

Student Pilot Flight Instruction Manual*

Welcome to the Tri-County R/C Club of NJ - Flight Instruction Program.

You are about to become a part of one of the best radio control flying club in the Central Jersey area. Our goal is to not just teach you to solo an aircraft, but to become a proficient pilot. While other clubs may make it easier for you, we want you to become a better pilot when you've earned your wings.

More importantly, we want you to be a safe pilot, for yourself, your fellow club members, and the sport itself. Please remember, model aircraft are not toys. Unsafe practices and procedures can result in serious injury. We are happy to provide all the assistance needed for you to get the most out of this hobby. This is a very rewarding hobby if a little effort is put in to learn it correctly from the start. Good luck - happy flying and safe landings!

Table of Contents

Disclaimer

Ground School

Field Procedures & Safety Guidelines

Aircraft Check Out & Maintenance Guideline

Flight Instruction

Disclaimer

The names Tri-County R/C Club of NJ, Tri-County R/C Flying Club, Tri-County Radio Control Club, TCRC Club etc. shall be synonymous. They shall be all inclusive of all members in good standing, be they club officers, board of directors, instructors or general membership as set forth by the club by- laws.

The Tri-County R/C Club of New Jersey assumes no liability or responsibility in regards to the material herein, or any resulting action thereof. All information was compiled in good faith from printed materials, past experience and general knowledge of the model aviation hobby.

Safety, safe practices and procedures, have been emphasized throughout this manual. Participants are expected to comply with these guidelines at all times as a member of the Tri-County R/C Club of NJ.

The Tri-County R/C Club flight assistance program is provided free of charge, by experienced model aircraft pilots who volunteer their time. There are no guarantees as to results. Participants must exercise their own good judgment and common sense in determining their abilities and limitations. Tri-County R/C Club of NJ assumes no liability or responsibility for any action taken, past, present, or future, by any participant in this program.

Participants further attest they are members in good standing with the Academy of Model Aeronautics. Should the possibility of conflict exist with club procedures, guidelines, etc. and A.M.A rules, A.M.A. rules will take precedence.

If you do not find these terms agreeable to your situation, please do not ask to participate in the program.

Ground School

The following section is mainly designed for those who have little or no knowledge of aerodynamics, and/or are totally new to the hobby. Even experienced pilots will benefit from this, as there are some differences between models and full scale. Please read it thoroughly.

First, if you are just starting out: There are benefits to getting an ARF (Almost Ready to Fly) as opposed to kits. Generally speaking, by the time you buy a kit, the hardware and the covering, you have spent as much as the ARF. And it will take you at least twice as long to put the kit together. You will also need the appropriate tools to install the covering. So too with an "Almost Ready to Cover" plane. And if you do destroy an ARF, you won't have the time investment loss. The advantage to the kit is you know how well it is constructed, and the covering will probably be better quality material. Keep in mind that covering the aircraft alone is an art in itself, and will probably take 10 to 15 hours. Build kits in the fall and winter; ARFs in the spring and summer.

Second, if you are just starting out: Don't load up your Visa/Mastercard with all kinds of equipment, flight boxes etc. Get some fuel and get to the field. After you've worked with an instructor, and met some fellow pilots, then decide what equipment you want. There is a lot to choose from. And there is a lot of good used equipment available through the club or swap meets. All too often, new hobbyists overspend, don't learn as quickly as they had hoped, and get discouraged. This is especially true if they tear up their first airplane. Keep your investment small until you gain some momentum.

Third, now that you've started: Unless you're sure of yourself, don't be too quick to buy that "second" plane. Chances are you may be buying a second "first" plane. Take your time. On the other hand, you may surprise yourself and be able to jump directly to a "third" or "fourth" plane. Get some flight time in after you've soled and you'll have a better idea.

We will not get into any discussions of model kit building, or radio systems at this time. Together they could have their own entire manual.

Granted, one doesn't have to know how to fly the space shuttle to fly a model aircraft. However, a general understanding of basic aerodynamics will help to understand why it does what it does. Our objective here is to provide you with the concept of aerodynamics, not the technicalities. For those who wish to go into aerodynamics at greater depth, student or private pilot flight manuals are a good place to start.

Note: Referring to aircraft as to right or left, is as a pilot would view it from the cockpit.

Wings:

There are three basic wing profiles.

Flat Bottom:

Creates the most lift and is the most stable. Most trainers are flat bottom.

Semi-Symmetrical:

Still stable, yet allows more maneuverability and extends aerobatic capability. Great for "second" planes.

Fully Symmetrical:

Least stable and most aerobatic. For more experienced flyers only. There are three basic wing locations.

High-Wing, Mid-Wing, Low-Wing:

Stability diminishes as the wing comes down; the high wing being the most stable. Here too, most trainers are high wing. A fully symmetrical, mid-wing with no dihedral is the most aerobatic.

Dihedral:

Dihedral is the angle in the wing when looking at it from front or rear. The more dihedral, the more stable and self recovering. The straighter, the more aerobatic but less stable. A low-wing aircraft requires more dihedral to be as stable as a high-wing, all other factors being equal.

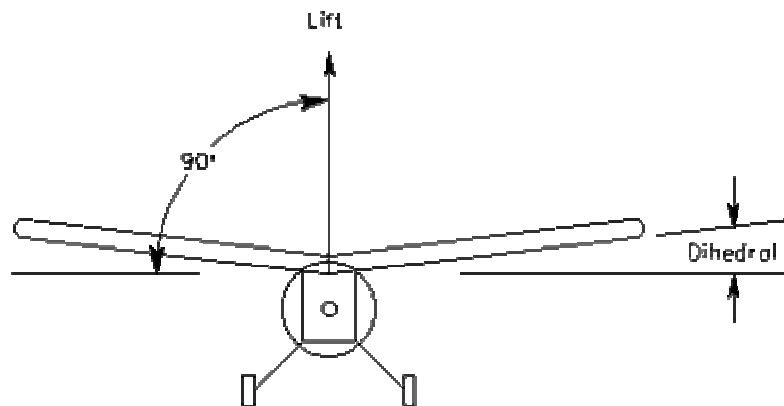

Washout:

Washout is a twisting of the wing when viewed from the wing tip. The trailing edge is higher at the wing tip than at the fuselage. This increases stability and self recovery. It allows the outer wing area to still "fly" (maintain control) even if the inner wing area is in a stall condition. Refer to "stalls" later. Washin is reverse, and has no practical application.

Ailerons:

Ailerons control the bank of the aircraft which turns the aircraft. Refer to "lift" later. The up aileron decreases "lift", while the down aileron creates more "lift", thereby banking the aircraft. The aircraft always banks or turns toward the up aileron.

Vertical Stabilizer:

The stationary part of the rudder assembly.

Rudder:

The movable control surface of the assembly. Its primary function is to coordinate the bank and turn. However, in the case of model aircraft, it can be used to steer or turn the craft.

Horizontal Stabilizer:

The stationary part of the elevator assembly.

Elevator:

The movable control surface of the assembly. Its primary function is to control the angle (nose up, etc) of the aircraft. However, in the case of model aircraft, it is basically used to control altitude. Technically, power controls altitude and elevator controls angle, which in turn controls airspeed. Refer to more advanced flight manuals.

Flaps:

Flaps create more "lift". There are several basic types of flaps, none of which are used on trainer planes. Refer to more technical manuals.

Lift:

Lift is created when the air moving over the top of the wing moves faster than the air underneath. Air over the top must travel a greater distance; therefore it must move faster to get to the rear at the same time. The faster the air moves past a surface, the less pressure it exerts on that surface. The pressure underneath is greater pushing the wing up. This is lift. Lift is always 90 degrees to the relative wind. Lift is always 90 degrees to the span of the wing.

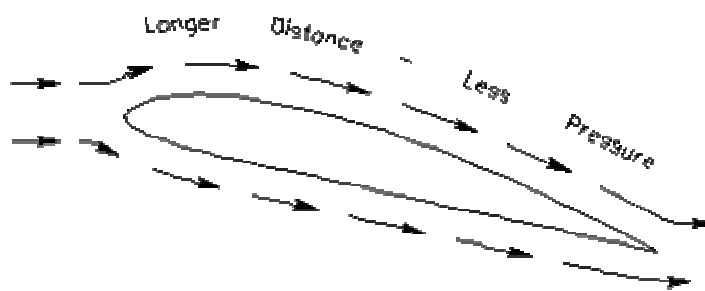
**Relative Wind:**

RW is the air coming at the aircraft; it is always exactly opposite the direction of travel. Do not confuse this with the wind conditions you are flying in. The angle of the wing as it hits the RW is called the angle of attack. Too high of an angle of attack, without enough airspeed, will cause the wing to stall. Refer to "stalls" later.

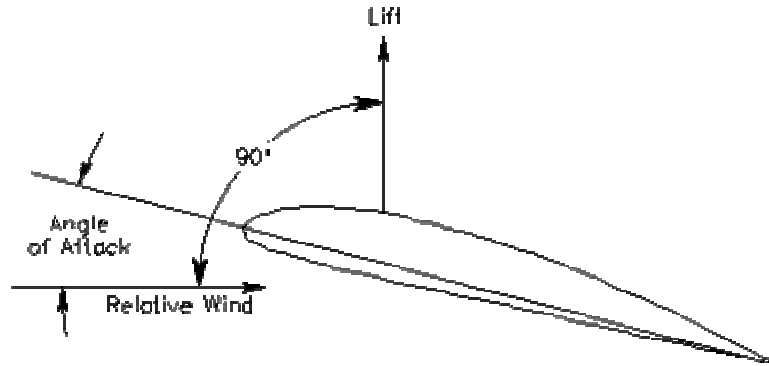

Components of lift:

When the aircraft is banked, the "lift" is banked too. The "vertical component of lift" is no longer as great. This is why you have to add up elevator to maintain altitude. The "horizontal component of lift" causes the aircraft to turn. If you bank too steep, the "vertical component" will lessen even more and the wing will stall and fall. Refer to "stalls" later.

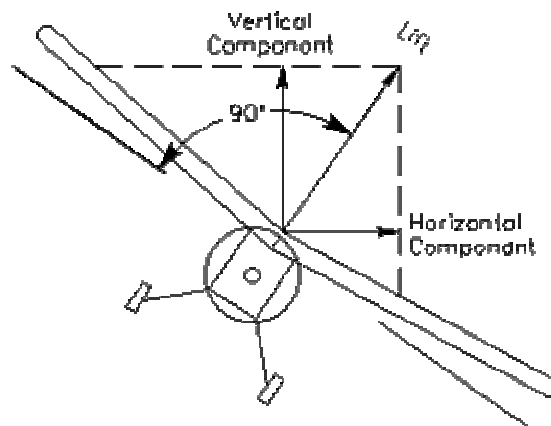

Propellers:

A propeller is nothing more than a rotating airfoil in the horizontal direction. Applying more power creates more horizontal lift (better known as thrust) which pulls the aircraft through the air. Do not think of a propeller as blowing air rearward.

P-Factor:

For the sake of simplicity we will only say that P-factor is the unequal thrust or torque of the propeller. During power on, or climbing conditions, the right side of the propeller produces more thrust. This causes the aircraft to drift left. This is why an aircraft that rolls straight, will run off to the left of the runway on take-off. Correct with a slight right rudder.

Stalls:

A stall is the loss of "lift". This condition occurs when the angle of attack becomes too great for the air to flow smoothly over the top surface. The air then becomes turbulent (much like the spoiler on a race car) and no longer produces lift. When this happens, the nose of the aircraft will drop abruptly resulting in the loss of altitude. Stalls can occur with power on, or power off, at low speed or high speed, depending on various other conditions. The most common are while climbing too steeply and turning after take-off, or when banking too steeply while turning final to land. All stalls have one thing in common. They all require lowering the nose to recover. Point of interest: A spin is nothing more than a sustained stall with rotation.

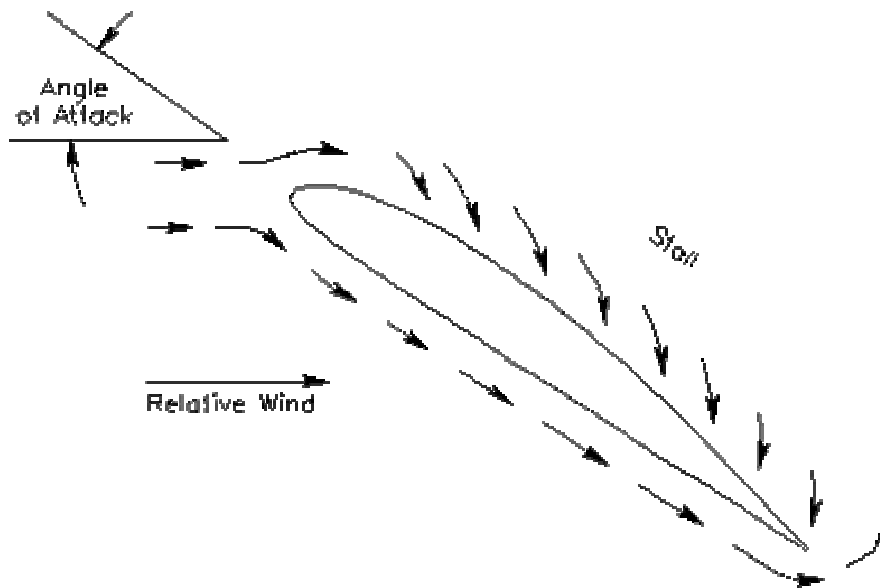

Flight Pattern:

The FP, or traffic pattern, is made up of four legs. Starting at the runway, the first 90 degree turn is the crosswind leg. The second 90 degree turn becomes the downwind leg which is parallel to the runway. The third turn is the base leg which is 90 degrees to the runway again. The fourth turn becomes the final leg towards the runway. Henceforth the term: "Turning final". Proper departure for the pattern is to turn only 45 degrees not depart straight out the crosswind leg. Proper approach and entry is to head in on a 45 degree angle towards the downwind leg. Aim for the end of the runway where you plan to set down. Turn downwind when you are at an appropriate distance away from the runway. Do not enter the pattern straight in on the downwind as you may encounter departing aircraft.

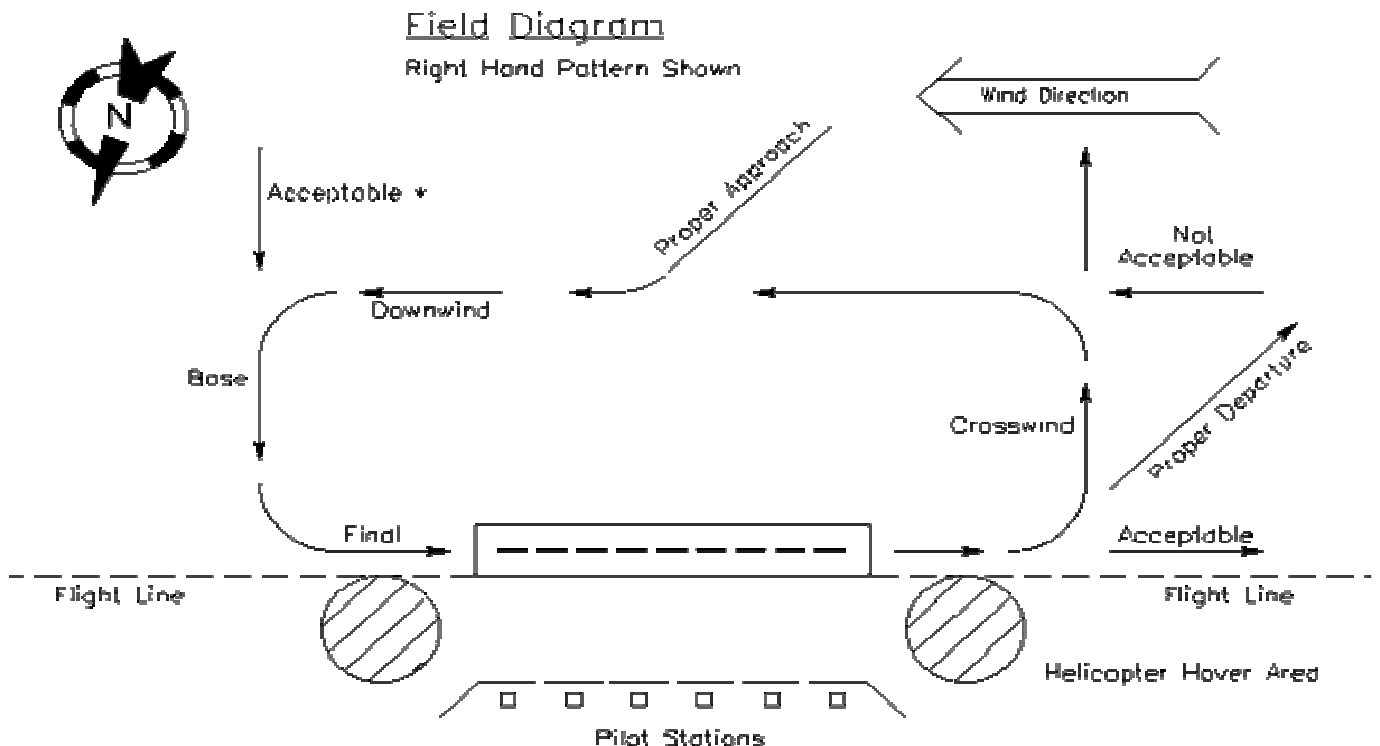

There are those who believe that flying a model aircraft is more difficult than a full scale. Visualizing yourself from the aircraft view takes some practice. It's like an out of cockpit experience. Everything is fine so long as you are coming towards yourself, is a whole different story. Think of it as sitting backwards on the dashboard of your car steering wheel between your legs, and driving down the road. Here's a reference list to help you along.

Aircraft Direction	
Control Movement	Aircraft Reaction
Aircraft Going Away	
Aileron	Same
Elevator	Same
Rudder	Same
Coming Towards You	
Aileron	Reversed
Elevator	Same
Rudder	Reversed
Inverted Going Away	
Aileron	Same
Elevator	Reversed
Rudder	Reversed
Inverted Coming Towards You	
Aileron	Reversed
Elevator	Reversed
Rudder	Same

Field Procedures & Safety Guidelines

It is the responsibility of all club members to abide by these simple guidelines. If you observe someone who isn't, please ask them to cooperate. They are designed to make our field the best and safest.

1. All A.M.A. rules apply. You must be a member of the Academy of Model Aeronautics to be a member of the Tri-County R/C Club of NJ with flying privileges. Tri-County R/C Club of NJ Constitution and By-laws provide for immediate suspension of membership of anyone in violation of A.M.A. rules.
2. Never, ever, turn on your transmitter, or test your equipment, at your vehicle, in the parking lot.
3. Do not turn on your transmitter unless you have placed your frequency pin on the board. Pins should have your name and/or A.M.A. number.
4. Never remove someone else's pin without their permission.
5. When you turn on your transmitter, check to see if any airborne aircraft are affected. Be prepared to turn yours off again!
6. Remove your frequency pin when you are not using your system.
7. Use fuel overflow catch cans or fuel mats. An old carpet remnant works well.
8. Never start a loose aircraft; get assistance. Use a safety hold down or a stooge. Do not start at full throttle; partial is usually sufficient.
9. Do not point prop blast or exhaust at spectators or other pit personnel.
10. Do not turn your back to the flight area, especially if you are at a pilot station.
11. Do not taxi your aircraft in the pit area. Carry it or hold on to it.
12. Fly only from pilot stations; not in an opening. Fly with a copilot/spotter.
13. Check control surface movement one last time before departing. Do not attempt to fly if anything is in doubt. Return to the pit area.
14. All flying will be north of the flight line, which is the northern edge of the runway. Do not take off directly from the pilot station line. Do not fly south the flight line.
15. Announce your intentions loud & clear: "taking off", "landing left", "landing right", "on the field", "dead stick", etc.
16. Take off & depart on the crosswind leg of the pattern. Enter the pattern on the downwind leg.
17. Do not fly over the parking lot and access road.
18. Police your area. Put trash (broken props, rubber bands, cigarette butts, etc.) into barrels. Your mother/wife doesn't fly here; you'll have to pick up after yourself.
19. Personnel who are not piloting an aircraft should refrain from disturbing, or distracting those who are.
20. Kite flying and model rocket operations are not permitted.
21. No spectators or pets in the pit area.

22. Talk to the spectators and answer their questions. If you are not comfortable in doing so, find someone who will. They are the future growth of the sport and our club. Everyone is a potential new member. Politely request that they remain behind the fence.
23. Above all else, conduct yourself in a professional and mature manner. Make club officers aware of those who don't. They are detrimental to our image.

Aircraft Check Out & Maintenance Guideline

The following items should be checked regularly, at least before the first flight every flight date. It is recommended that most items be checked after each flight date, at home, so there will be no surprises at the field next time out. Do not fly aircraft that does not pass all of these criteria.

1. Propeller & spinner secure - propeller properly balanced & undamaged - Do not use a damaged propeller.
2. Engine bolts secure to mount - Mount secure to firewall.
3. Fuel tank secure, preferably in foam rubber - Tank clunk free.
4. Receiver, battery, all servos secure - Receiver in rubber - Wires clear of all moving control horns & pushrods - Antenna clear of servos.
5. Minimal free play in servo horns & pushrods - Control horns secure - Clevis' secure with safety retainers.
6. All control surface hinges secure (especially ARFs) with minimal gap - Free movement (no binds) all control surfaces - Rudder, elevator, ailerons
7. Throttle travel, idle to full - Shut off travel OK - No servo bind at full throttle (nothing drains a battery more than a servo bind.)
8. Nose wheel straight, at least sensitive position - Roll test on pavement
9. Aileron servo connected - Retainer or baffle to keep aileron wire from entangling in aileron rods.
10. Rubber band quantity & installation - Do not use old or used rubber bands. Recommended installation: 2 criss-cross, 6 straight (3 each side), 4 criss-cross
11. Balance empty (no fuel) - Do not fly a tail heavy aircraft. Remember, a nose heavy plane flies sluggish; a tail heavy plane usually only flies once.
12. AMA number & proper identification - Name and address inside
13. Receiver battery voltage - Do not operate below 4.9 volts.

Flight Instruction

Guideline of Maneuvers

This section is not intended to teach you the mechanics of flying an aircraft. That is left to the instructors. Rather, its purpose is to give you an overview of what to expect, what you should know, and the sequence to learn.

It is expected that all student pilots fly with more than one instructor. Each individual instructor has his own methods and techniques. What works for one, may not work for another. It is wise to get exposure to several and decide for yourself. Remember however, the basics of aerodynamics never change.

Most students can expect to fly 2 or 3, 10 to 15 minute flights each time out. Most can expect to have 5 or 6 of these sessions before earning their "wings". Don't get discouraged. Some students struggle along until one day everything just clicks, and then it's: "Hey look, I'm doing it!"

Familiarize yourself with the transmitter. Practice at home. You should be as familiar with it as you are with the location of the controls of your car, or a ten speed bike.

Likewise, before any flight instruction, familiarize yourself with the "Field Procedures" and "Flying & Safety Tips" in this manual. Make safety your number one priority.

Here's an exercise any combination of pilots can try. It works best with an instructor and two students. One student holds the aircraft while the instructor works with the other student and the transmitter. As the student on the TX works the controls, the student holding the plane maneuvers it. This is great for "coming at you orientation". And if he doesn't level out those ailerons, just keep rolling until inverted. This saves a lot of aircraft from needless repairs! Try it, it works. And don't forget to hang up a frequency tag while doing this exercise.

Note: There are computer model aircraft flight simulators available. They may, or may not help you in the leading process. The general opinion still remains that there is nothing like actual "stick" time. Simulators are probably better suited to help you experiment with more advanced maneuvers after you've soloed.

Basics of Pre-Flight: Refer to "Aircraft Check Out Guideline"

- Check receiver battery
- Fill fuel tank to full
- Frequency tag on board
- Transmitter on

- Receiver on
- Check controls
- Start engine
- Range check
- Check engine vertical running
- Check engine idle and shut off
- Carry aircraft to pilot station line
- Full extend transmitter antenna*
- Final check controls

*Optional: For those using the buddy box system; student may pull buddy box antenna part way out to get in the habit. Note: Buddy box power is always "off". Never turn buddy box power "on"!

Post Flight Shut-Down:

- Taxi to pilot station
- Shut off engine
- Turn off receiver
- Turn off transmitter
- Carry back to pit area
- Reset any controls as necessary
- Transmitter off again
- Remove frequency tag from board**

**Suggestion: Place your frequency tag somewhere you have to move it again to go flying. Hang it over transmitter, engine, wing etc. Your back pocket or in the flight box is not a good location. In your haste to fly with an available instructor, you will probably forget to hang it on the board.

The time has come to start putting this all together.

Ground Taxi:

Student may practice on his/her own. Suggest developing skills with wing off. Especially practice "coming at you" orientation. Practice running up and down the runway at higher speed. Suggest moving aileron stick at same time to develop association.

Straight & Level Flight:

Instructor will take off and trim the aircraft. He will hand off to you to teach you simple elevator and aileron usage. He will re-trim aircraft as necessary.

Turns:

Apply up elevator to maintain altitude. Do not exceed 30 degrees of bank. Coordinate with slight rudder. Get comfortable just driving around in the sky.

Oval (Racetrack) Patterns:

Practice a combination of previously learned skills. Develop consistency by repeating pattern. Practice both left and right.

Figure 8 Patterns:

Practice maintaining altitude while developing left to right, and right to left transition and coordinate.

Rudder Only Turns:

Develop ability to pilot aircraft should ailerons ever fail. Practice previously learned maneuvers.

Slow Flight:

Practice previous maneuvers at reduced speeds. Learn how to re-trim the aircraft. Learn how power settings affect altitude and elevator controls.

Approach & Go-Around:

Learn the flight pattern. Practice low flight line fly-bys. Left and right hand patterns required.

Stalls:

Learn the proper recovery from power off, power on, turning stalls. Learn to recognize the situation before it happens.

Take-Offs:

For the first several take-offs, student to stand behind the aircraft at the end of the runway. Straight out departure until gaining sufficient altitude before turning. Practice trimming aircraft after climbing to a safe altitude.

Simple Aerobatics:

Exposure to loops and inverted flight by instructor. Student will help develop his own confidence while learning recovery techniques.

Unusual Attitudes: (Not to be confused with a weird sense of humor)

Experience recovery from inverted flight, spins etc. Instructor to demonstrate. Student should be able to recover from an inverted situation.

Landings:

Practice proper entry into the pattern and develop judgment skills; power vs. Altitude. Left and right patterns required. Instructor to demonstrate simulated dead stick from a distance out. Be careful not to bank too steep in the pattern at low speed, especially from base leg to final.

Advanced Aerobatics:

Optional, but recommended. Learn aileron rolls, barrel rolls, sustained inverted flight, immelman turns & cuban eights. For the brave; split-S and spins. You've already learned some of this recovering from inverted. Develop better coordination skills and build your confidence.

Turbulence Flying:

The day will come when you say to yourself: "I shouldn't be up here!" That thought usually occurs soon after you've soloed, just after pattern departure, and you suddenly realize you're already over the trees. Don't panic. Keep your cool. Although not required, it is a good experience to go up with an instructor on a turbulent day. Scary as it is, it teaches you how to stay on top of a situation where the aircraft is almost out of control. A windy day can blow you too far away for orientation, or turn you inverted in a heartbeat. Keep your bank shallow on windy days. Landings require partial power on, especially crosswind.

By now you should be driving around in the sky by yourself, and loving every minute of it. You should be proud of your accomplishments. Please check out the following section on Flying & Safety-tips & Hints if you haven't done so already. You will find it very helpful.

Thank you for choosing the Tri-County R/C Club of NJ for your model aviation experience. We look forward to many years together. Remember, shiny side up, greasy side down!

*(The above text was adapted from Palos R/C Club - Edited by: Alexander Szemere, Flight Instructor)